



### KEY FEATURES

- Passive two-way point source
- Compact lightweight enclosure
- 6" woofer, 1" HF compression driver
- Asymmetric HF coverage pattern
- Rotatable HF horn
- Non-symmetrical, multi-angled enclosure
- M8 and M6 flying points
- Pole mount socket
- Black or white finish

### APPLICATIONS

- Distributed systems
- Theatre underbalcony
- Corporate and A/V
- TV and broadcast
- Stage monitoring
- Near fill and front fill
- Live music venues
- Bars and restaurants
- House of Worship
- Retail outlets

### TECHNICAL SPECIFICATIONS

#### SYSTEM

System's Acoustic Principle	Two-way Vented Enclosure Asymmetric Dispersion
Frequency Response (-6dB)	85 Hz – 18 kHz
Nominal Impedance	16 ohm
Horizontal/ Vertical Coverage Angle	70° to 120° asymmetric, (-6dB) / 60° averaged, 1kHz to 20kHz (-6dB)
Sensitivity 4V	92 dB SPL @ 1m
Maximum (peak) Output	114 dB SPL @ 1m

#### TRANSDUCERS

LF	One 6" (152mm) LF driver, 1.5" (38mm) aluminium voice coil, 16Ω
HF	One 1" (25.4mm) HF compression driver, 1" (25.4mm) aluminium voice coil, 16Ω

#### INPUT CONNECTIONS

Connector Type	Neutrik® speakON™ NL4MP x 2
----------------	-----------------------------

#### POWER HANDLING

Input Power Rating (AES)	100 W
Input Power Handling (Program)	200 W

#### ENCLOSURE & CONSTRUCTION

Dimensions (W x H x D)	210 mm (8.3") x 390 mm (15.3") x 190 mm (7.5")
Taper	Stage Monitor: 35° - Frontfill: 7.5°
Enclosure Material	15mm, reinforced phenolic birch
Paint	High resistance, black or white water based paint
Flying System	M8 / M6 flying points or dedicated metal brackets
Net Weight	5kg (11 lbs)



## DESCRIPTION

The ED60P is a compact, lightweight, two-way passive point source loudspeaker that provides great performance from a very discreet and easily manageable enclosure. It is designed for sound reinforcement applications requiring high quality sound and accurate reproduction in a space-saving format.

The 6" low frequency driver is matched to a 1" high frequency compression driver, both components using aluminium voice coils for low weight and good transient response, with an audiophile-grade passive crossover.

The ED60P's non-symmetrical vented enclosure allows it to adapt to multiple portable and fixed applications, such as front-of-house duties on a speaker stand, or pole mounted on an associated subwoofer or, by using the 35° wedge angle, as a very compact and low profile stage monitor. In addition the 7° angled sides enable it to be deployed as a discreet stage lip front fill loudspeaker.

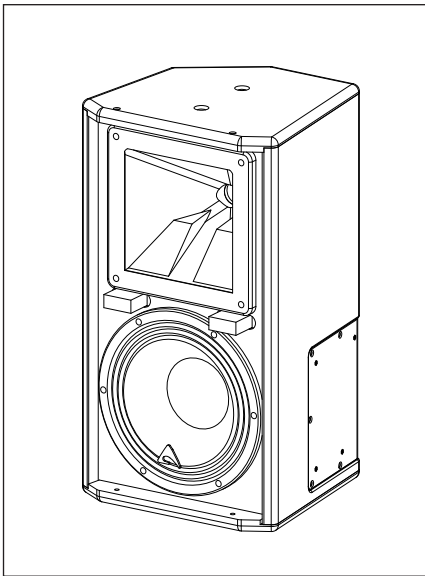

A key feature of the ED60P is its asymmetrical high frequency coverage pattern, varying from 120° horizontal in the lower part of the horn for more effective near field coverage, and narrowing to 70° horizontal at the top of the horn for more focused coverage in the far field. The result is more accurate coverage of a typical auditorium than is possible with a fixed horizontal coverage device.

The HF horn is also rotatable through 90° by simply removing four screws and re-aligning the horn, so that in a stage monitor mode the asymmetrical pattern optimises coverage for performers both near to, and further away from, the monitor. This rotatable horn feature also makes it possible to maintain the ideal coverage pattern when the cabinet is installed in a horizontal (landscape) format.

The 15mm phenolic birch plywood cabinet is provided with a 35mm pole mount, a recessed handle for easy lifting and handling, and M8 rigging points to allow suspension in fixed installations using optional mounting brackets. Two Neutrik® speakON™ NL4 connectors provide input and link connections.

To extend the system's low frequency response the ED60P can be complemented by subwoofers from the Axiom SW series such as the SW210P or SW18P.

## MOUNTING AND FIXING

The ED60P can be wall mounted in permanent installations either vertically or horizontally using the KPTED60B wall bracket. The wall bracket allows seven steps of incremental rotational adjustment to enable the loudspeaker to be accurately aimed. When mounted horizontally the loudspeaker's asymmetrical HF waveguide can be rotated through 90° within the enclosure to maintain the optimum coverage pattern.

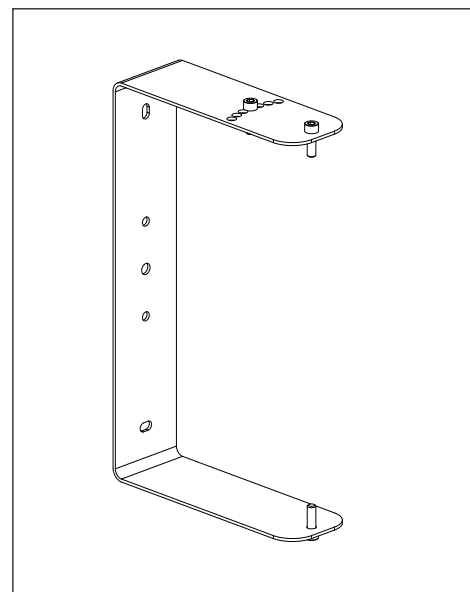

## ED60P frequency response

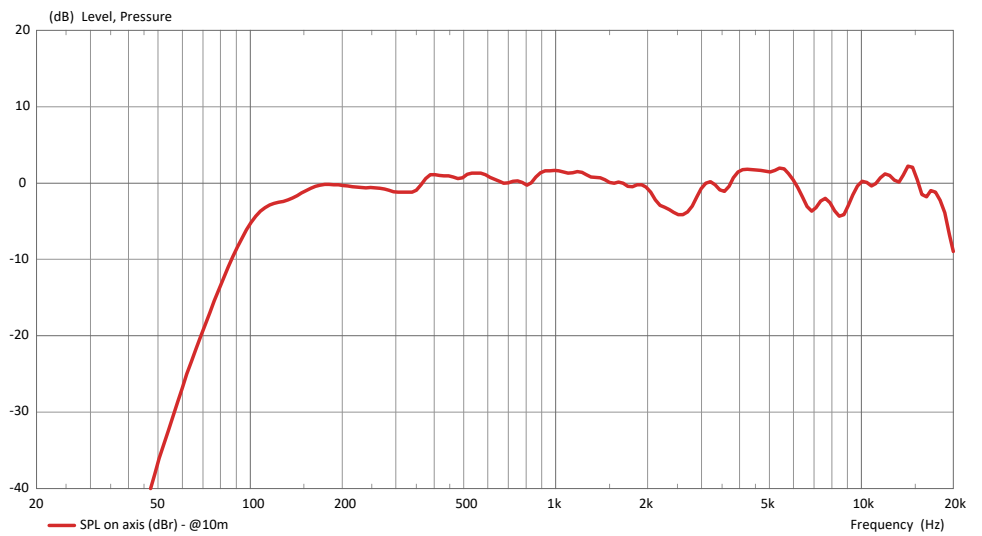

## ED60P HORIZONTAL directivity map

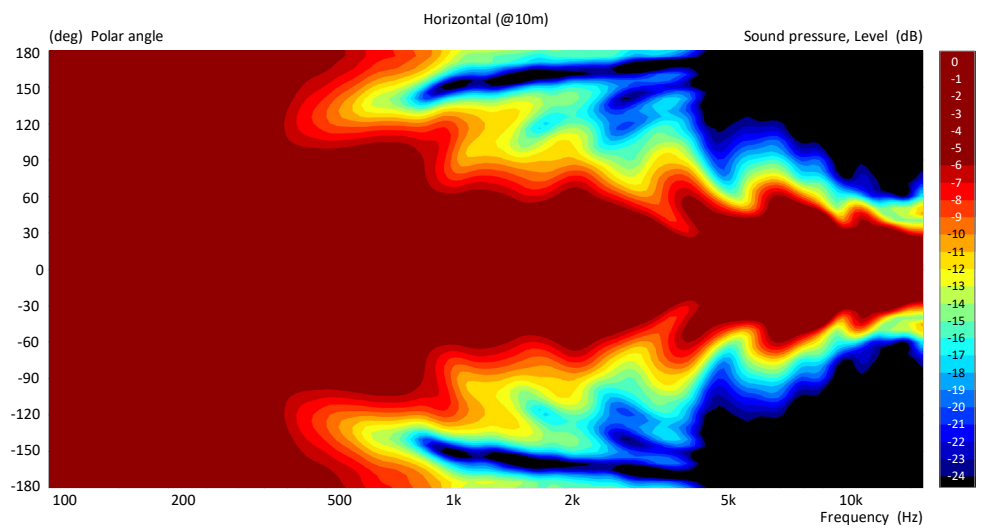

## ED60P VERTICAL directivity map

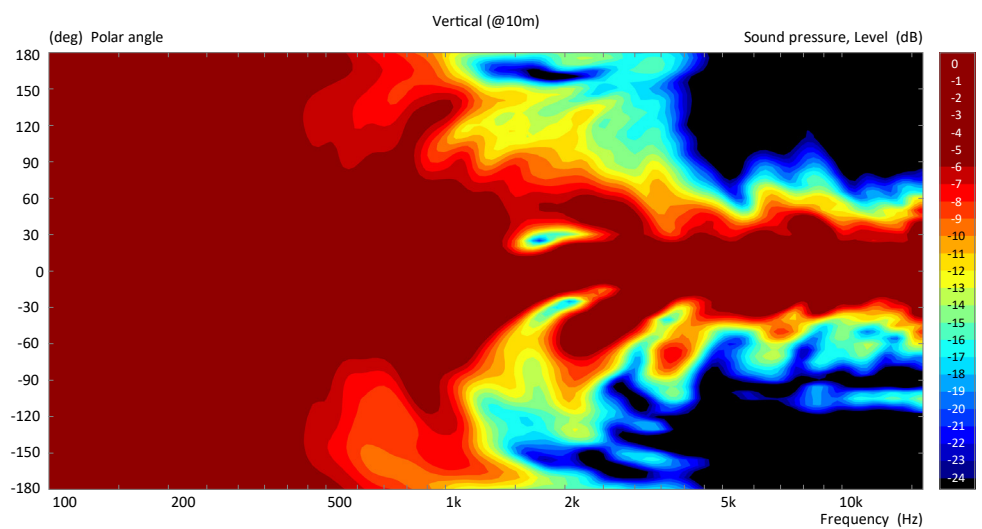

## ED60P HF HORIZONTAL polar diagram

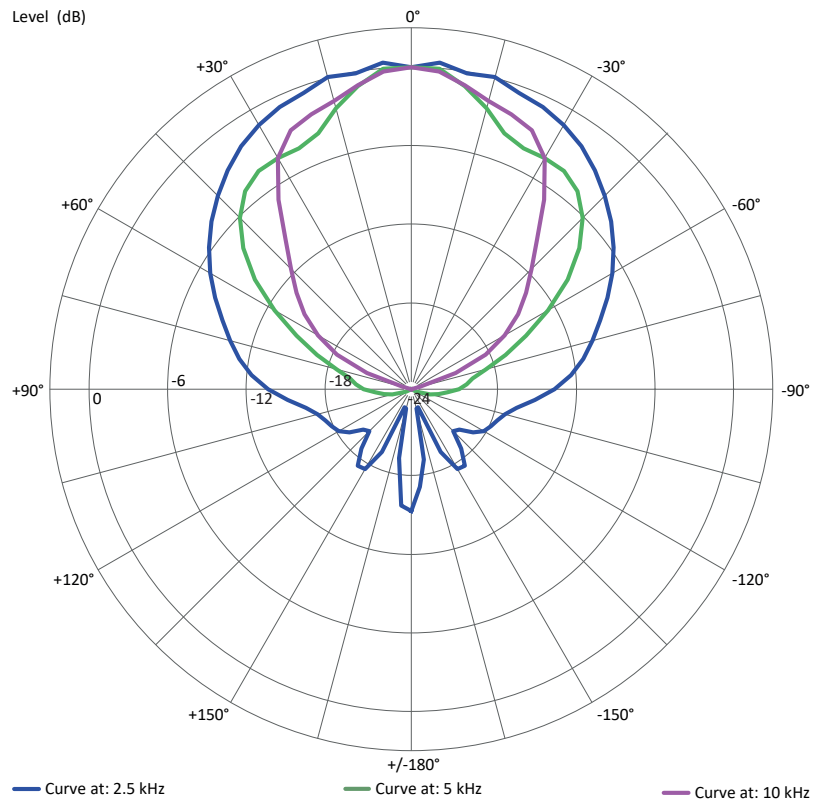

## ED60P HF VERTICAL polar diagram

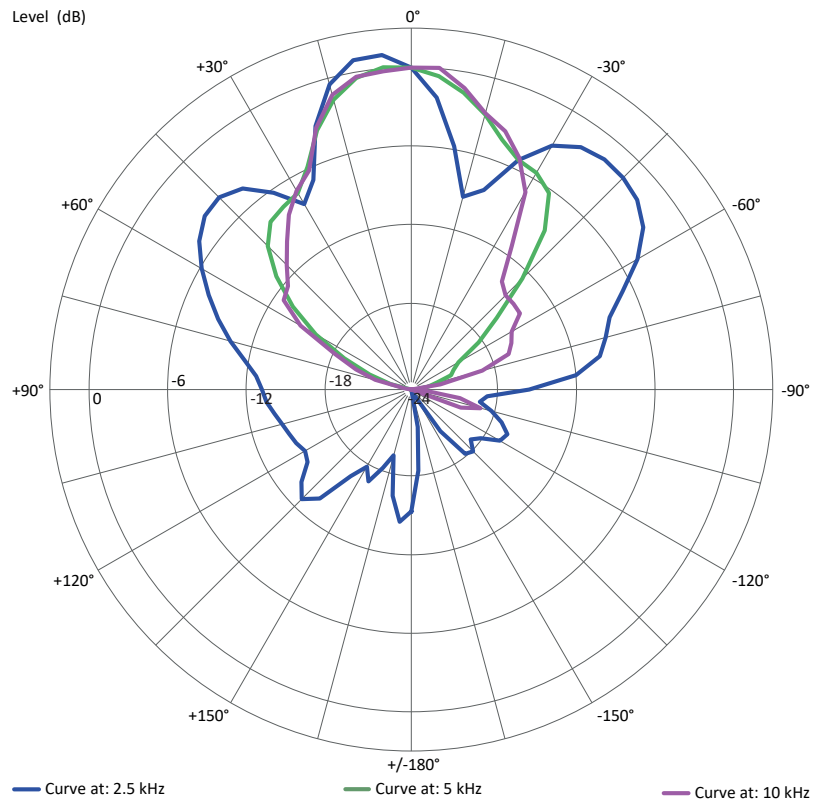

## ED60P LF HORIZONTAL polar diagram

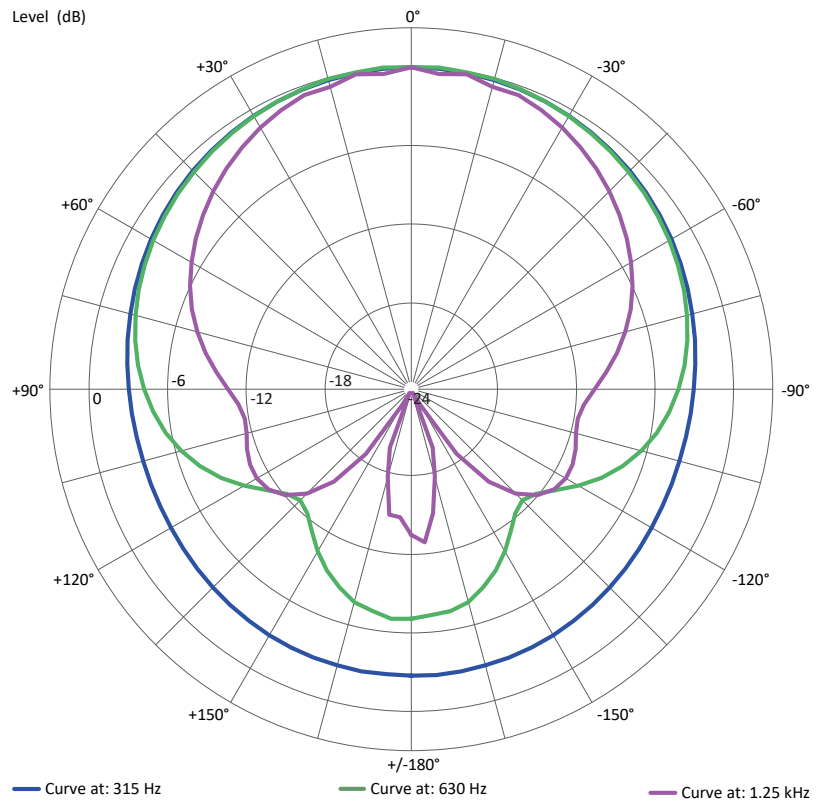

## ED60P LF VERTICAL polar diagram

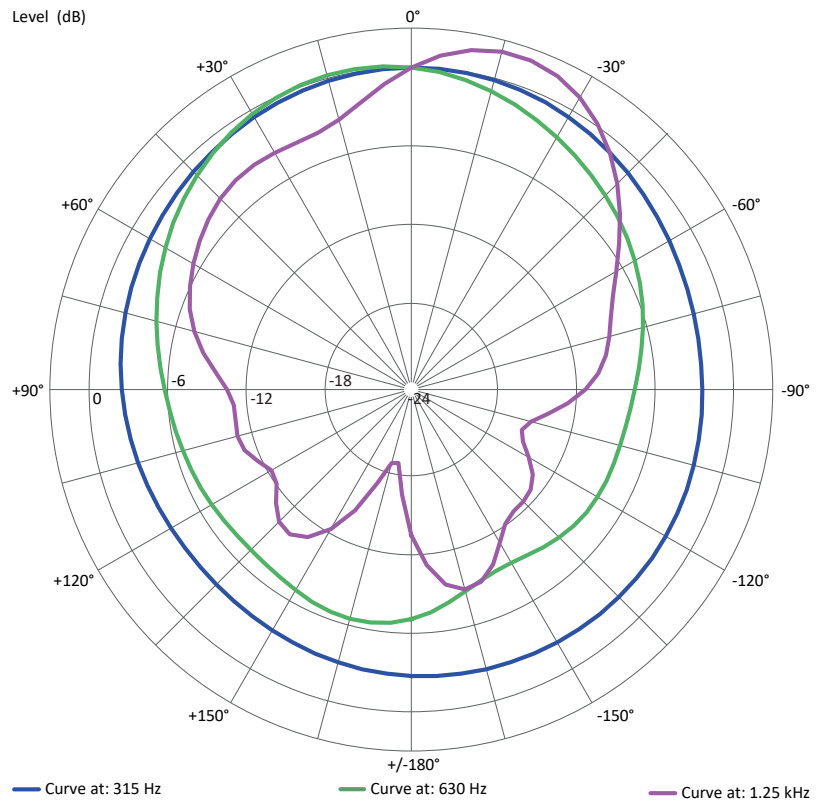

## ENGINEERING DRAWING

